



SELLOS MECÁNICOS

GARNITURES MÉCANIQUES

108 / 109

MECHANICAL SEALS

GLEITRINGDICHTUNGEN

Sellos Mecánicos
Garnitures Mécaniques
Mechanical Seals
Gleitringdichtungen

108 / 109



Sello mecánico no equilibrado, muelle simple, sentido de rotación dependiente.
Garniture mécanique non équilibrée, ressort simple, sens de rotation dépendant.
Unbalanced mechanical seal, single spring, dependent on direction of rotation.
Nicht entlastete Gleitringdichtung, einfache Feder, drehrichtungsabhängig.

TABLA DIMENSIONAL (Dimensiones en mm. sujetas a variaciones o modificaciones)

TABLEAU DIMENSIONNEL (Dimensions en mm. sujettes à variations ou modifications)

Ref.	d ₁	d ₃	d ₆	d ₇	d ₈	d ₁₁	d ₁₂	l ₃	l ₅	l ₆	l ₇	l ₈	l ₉	l ₁₀	l ₁₁	l ₁₂	l ₁₃	l ₁₄	l ₁₅	l ₁₆	l ₂₁	l ₂₈
10	10	19	17	21	3	15.5	19.2	15.5	1.5	4	8.5	17.5	10.0	7.5	9.0	7.5	7.1	6.6	1.2	3.8	15.5	6.6
12	12	21	19	23	3	17.5	21.6	16.0	1.5	4	8.5	17.5	10.0	7.5	10.0	6.5	7.6	5.6	1.2	3.8	15.5	6.6
14	14	23	21	25	3	20.5	24.6	16.5	1.5	4	8.5	17.5	10.0	7.5	10.0	6.5	7.6	5.6	1.2	3.8	15.5	6.6
15	15	24	--	--	--	20.5	24.6	--	--	--	--	--	--	--	11.0	7.5	8.6	6.6	1.2	3.8	15.5	--
16	16	26	23	27	3	22.0	28.0	18.0	1.5	4	8.5	17.5	10.0	7.5	11.5	8.5	9.0	7.5	1.5	5.0	17.5	6.6
18	18	29	27	33	3	24.0	30.0	19.5	2.0	5	9.0	19.5	11.5	8.5	12.5	9.0	10.0	8.0	1.5	5.0	18.5	7.5
20	20	31	29	35	3	29.5	35.0	22.0	2.0	5	9.0	19.5	11.5	8.5	12.5	8.5	9.5	7.5	1.5	5.0	20.0	7.5
22	22	33	31	37	3	29.5	35.0	21.5	2.0	5	9.0	19.5	11.5	8.5	12.5	8.5	9.5	7.5	1.5	5.0	21.5	7.5
24	24	35	33	39	3	32.0	38.0	23.5	2.0	5	9.0	19.5	11.5	8.5	12.5	8.5	9.5	7.5	1.5	5.0	23.0	7.5
25	25	36	34	40	3	32.0	38.0	26.5	2.0	5	9.0	19.5	11.5	8.5	12.5	8.5	9.5	7.5	1.5	5.0	24.5	7.5
26	26	37	--	--	--	34.0	40.0	--	--	--	9.0	--	--	--	13.0	9.0	10.0	8.0	1.5	5.0	24.5	--
28	28	40	37	43	3	36.0	42.0	26.5	2.0	5	9.0	19.5	11.5	8.5	14.0	10.0	11.0	9.0	1.5	5.0	24.5	7.5
30	30	43	39	45	3	39.2	45.0	26.5	2.0	5	9.0	19.5	11.5	8.5	14.0	11.5	11.0	10.5	1.5	5.0	24.5	7.5
32	32	46	42	48	3	42.2	48.0	28.5	2.0	5	9.0	19.5	11.5	8.5	14.0	11.5	11.0	10.5	1.5	5.0	28.0	7.5
33	33	47	42	48	3	--	--	28.5	2.0	5	9.0	19.5	11.5	8.5	--	12.0	--	--	--	--	--	7.5
35	35	49	44	50	3	46.2	52.0	28.5	2.0	5	9.0	19.5	11.5	8.5	14.5	12.0	11.5	11.0	1.5	5.0	28.0	7.5
38	38	53	49	56	4	49.2	55.0	33.5	2.0	6	9.0	22.0	14.0	10.0	14.5	11.3	11.5	10.3	1.5	5.0	31.0	9.0
40	40	56	51	58	4	52.2	58.0	36.0	2.0	6	9.0	22.0	14.0	10.0	14.5	11.8	11.5	10.8	1.5	5.0	34.0	9.0
42	42	59	--	--	--	53.3	62.0	--	--	--	9.0	--	--	--	17.0	13.2	14.3	12.0	2.0	6.0	35.0	--
43	43	59	54	61	4	--	--	38.5	2.0	6	9.0	22.0	14.0	10.0	--	13.2	--	--	2.0	--	--	9.0
45	45	61	56	63	4	55.3	64.0	39.5	2.0	6	9.0	22.0	14.0	10.0	17.0	12.8	14.3	11.6	2.0	6.0	36.5	9.0
48	48	64	59	66	4	59.7	68.4	46.0	2.0	6	9.0	22.0	14.0	10.0	17.0	12.8	14.3	11.6	2.0	6.0	42.0	9.0
50	50	66	62	70	4	60.8	69.3	45.0	2.5	6	9.0	23.0	15.0	10.5	17.0	12.8	14.3	11.6	2.0	6.0	43.0	9.5
53	53	69	65	73	4	--	--	47.0	2.5	6	9.0	23.0	15.0	12.0	--	13.5	--	--	--	--	--	11.0
55	55	71	67	75	4	66.5	75.4	49.0	2.5	6	9.0	23.0	15.0	12.0	18.0	14.5	15.3	13.3	2.0	6.0	47.0	11.0
58	58	76	70	78	4	69.5	78.4	55.0	2.5	6	9.0	23.0	15.0	12.0	18.0	14.5	15.3	13.3	2.0	6.0	50.0	11.0
60	60	78	72	80	4	71.5	80.4	55.0	2.5	6	9.0	23.0	15.0	12.0	18.0	14.5	15.3	13.3	2.0	6.0	51.0	11.0
63	63	83	75	83	4	--	--	55.0	2.5	6	9.0	23.0	15.0	12.0	--	14.2	--	--	--	--	--	11.0
65	65	84	77	85	4	76.5	85.4	55.0	2.5	6	9.0	23.0	15.0	12.0	18.0	14.2	15.3	13.0	2.0	6.0	52.0	11.0
68	68	88	81	90	4	82.7	91.5	55.0	2.5	7	9.0	26.0	18.0	12.5	19.0	14.9	16.0	13.7	2.0	6.0	53.0	11.3
70	70	90	83	92	4	83.0	92.0	57.0	2.5	7	9.0	26.0	18.0	12.5	18.0	14.2	15.3	13.0	2.0	6.0	54.0	11.3
75	75	98	88	97	4	90.2	99.0	62.0	2.5	7	9.0	26.0	18.0	12.5	18.0	15.2	15.3	14.0	2.0	6.0	55.0	11.3
80	80	100	95	105	4	95.2	104.0	61.8	3.0	7	9.0	26.2	18.2	13.0	19.0	16.2	16.3	15.0	2.0	6.0	58.0	12.0

DIMENSIONS TABLE (Measures in mm. subject to change)

TABELLE DER ABMESSUNGEN (In mm. Abweichungen oder Änderungen vorbehalten)

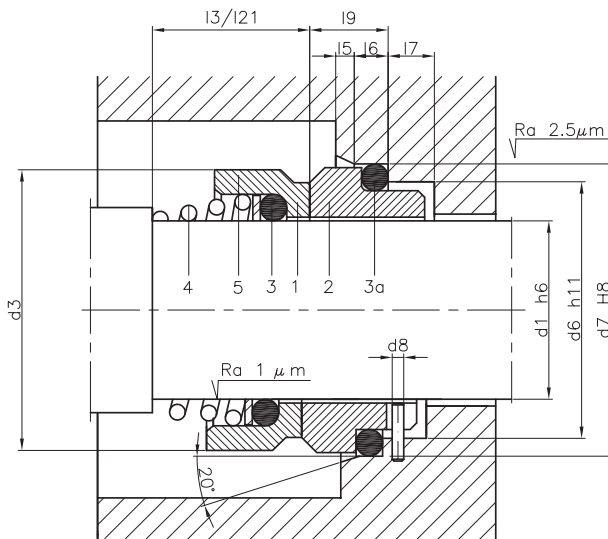

Tipos de Partes Fijas / Profils de Grains Fixes / Types of Stationary Seat / Typen stationärer Teile

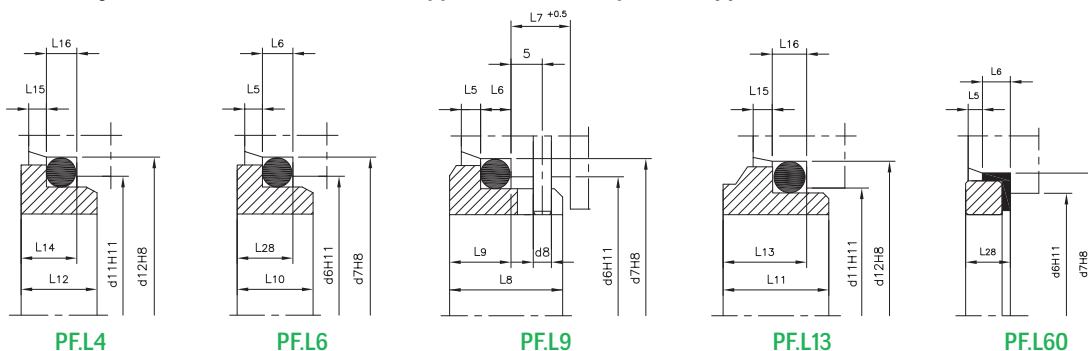

Tipo/Type/Typ 108: longitud de la parte rotativa l_3 / longueur de montage de la partie tournante l_3
axial fitting length of rotating part l_3 / Montagelänge des rotierende Teils l_3

Tipo/Type/Typ 109: longitud de montaje de la parte rotativa l_2 / longueur de montage de la partie tournante l_2
axial fitting length of rotating part l_2 / Montagelänge des rotierende Teils l_2

LÍMITES OPERATIVOS / LIMITES D'UTILISATION / OPERATING LIMITS / EINSATZGRENZEN

d_1 = 10 ÷ 80 mm

p/d = 10 Kg/cm²

v/g = 20 m/s

t = -20 ÷ +200°C

Los límites operativos vienen condicionados por el factor PV
Les limites d'utilisation ci-dessus peuvent varier en fonction du facteur PV
The operating limits depend on the PV factor
Die Einsatzgrenzen werden durch den DG-Faktor festgelegt

MATERIALES / MATÉRIAUX / MATERIALS / MATERIALIEN

BGEGG	BVEGG	UBPGG
BGPGG	BVPGG	UBVGG
BGVGG	BVGG	UBEGG
BGMGG	BVMGG	UBMGG
BQEGG	QQEGG	UUEGG
BQPGG	QQPGG	UUPGG
BQVGG	QQVGG	UUVGG
BQMGG	QQMGG	UUMGG

Existen otras combinaciones de materiales
Il existe d'autres combinaisons de matériaux
Available in other materials
Es gibt andere Materialkombinationen

COMPONENTES / CONSTRUCTION / COMPONENTS / KOMPONENTEN

- 1 Cara de roce rotante / Grain mobile / Rotative face / Rotierende Gleitfläche
- 2 Cara de roce fija / Grain stationnaire / Stationary face / Stationäre Gleitfläche
- 3 Junta tórica / Joint torique / O-ring
- 3a Junta tórica / Joint torique / O-ring
- 4 Muelle / Ressort / Spring / Feder
- 5 Armadura metálica / Corps / Metal frame / Metallgestell



LIDERING, S.A.

Pg. Ferrocarrils Catalans, 106-108 • 08940 Cornellà de Llobregat BARCELONA

Domestic Sales: 902 480 440

International Sales: +34 93 480 44 22

Fax 93 480 44 04



Pollensa, 2, Ofic. 8. Edif. Artemisa - Tartessos

28290 Las Rozas MADRID

Tel. 902 480 440 • Fax 91 361 40 20

LIDERING, S.A.R.L.

Parc des Aqueducs • Chemin du Favier RD 42 • 69230 Saint-Genis-Laval FRANCE

Tél. 04 72 67 02 67 • Fax 04 78 56 04 08

LIDERING, GmbH

Schiessstraße, 55 • 40549 Düsseldorf DEUTSCHLAND

Tel. 00 34 93 480 44 22 • Fax 00 34 93 480 44 04

S.A. LIDERING N.V.

BP 10 • 1410 Waterloo BELGIQUE-BELGIË

Tél. 00 34 93 480 44 22 • Fax 00 34 93 480 44 04

<http://www.lidering.com>

email: info@lidering.com