



SELLOS MECÁNICOS

GARNITURES MÉCANIQUES

271

MECHANICAL SEALS

GLEITRINGDICHTUNGEN

Sellos Mecánicos
Garnitures Mécaniques
Mechanical Seals
Gleitringdichtungen

271



Sello mecánico con longitud axial muy reducida. Puede montarse interno o externo. Sentido de rotación independiente.

Garniture mécanique de longueur axiale très réduite. Montage interne ou externe. Sens de rotation indépendant.

Mechanical seal with a short working length. Can be used as internal or external seal. Independent on direction of rotation.

Gleitringdichtung mit stark verringerter axialer Baulänge. Kann innen oder außen montiert werden. Drehrichtungsunabhängig.

TABLA DIMENSIONAL (Dimensiones en mm. sujetas a variaciones o modificaciones)

TABLEAU DIMENSIONNEL (Dimensions en mm. sujettes à variations ou modifications)

Ref.	d ₁	d ₃	d ₄	d ₆	d ₇	d ₈	l ₁	l ₃	l ₄	l ₆
16	16	27	31	27	27	3	27.7	19.1	8.6	7
18	18	29	33	27	33	3	29.1	19.1	10.0	9
20	20	32	36	29	35	3	29.1	19.1	10.0	9
22	22	34	38	31	37	3	29.1	19.1	10.0	9
24	24	34	38	33	39	3	29.1	19.1	10.0	9
25	25	35	39	34	40	3	29.1	19.1	10.0	9
28	28	40	44	37	43	3	29.1	19.1	10.0	9
30	30	41	45	39	45	3	29.1	19.1	10.0	9
32	32	43	47	42	48	3	29.1	19.1	10.0	9
33	33	44	48	42	48	3	29.1	19.1	10.0	9
35	35	46	50	44	50	3	29.1	19.1	10.0	9
38	38	52	56	49	56	4	32.1	21.1	11.0	10
40	40	55	59	51	58	4	32.1	21.1	11.0	10
43	43	58	62	54	61	4	32.1	21.1	11.0	10
45	45	60	64	56	63	4	32.1	21.1	11.0	10
48	48	62	66	59	66	4	32.1	21.1	11.0	10
50	50	62	66	62	70	4	34.1	21.1	13.0	11
53	53	71	75	65	73	4	34.1	22.1	13.0	11
55	55	72	76	67	75	4	34.1	22.1	13.0	11
58	58	78	82	70	78	4	38.8	25.8	13.0	11
60	60	79	83	72	80	4	38.8	25.8	13.0	11
63	63	79	83	75	83	4	38.8	25.8	13.0	11
65	65	87	91	77	85	4	38.8	25.8	13.0	11
68	68	89	93	81	90	4	41.1	25.8	15.3	12
70	70	89	93	83	92	4	41.1	25.8	15.3	12
75	75	96	100	88	97	4	41.1	25.8	15.3	12
80	80	101	105	95	105	4	41.5	25.8	15.7	13
85	85	108	112	100	110	4	41.5	25.8	15.7	13
90	90	113	117	105	115	4	41.5	25.8	15.7	13
95	95	116	120	110	120	4	41.5	25.8	15.7	13
100	100	121	125	115	125	4	41.5	25.8	15.7	13

DIMENSIONS TABLE (Measures in mm. subject to change)

TABELLE DER ABMESSUNGEN (In mm. Abweichungen oder Änderungen vorbehalten)

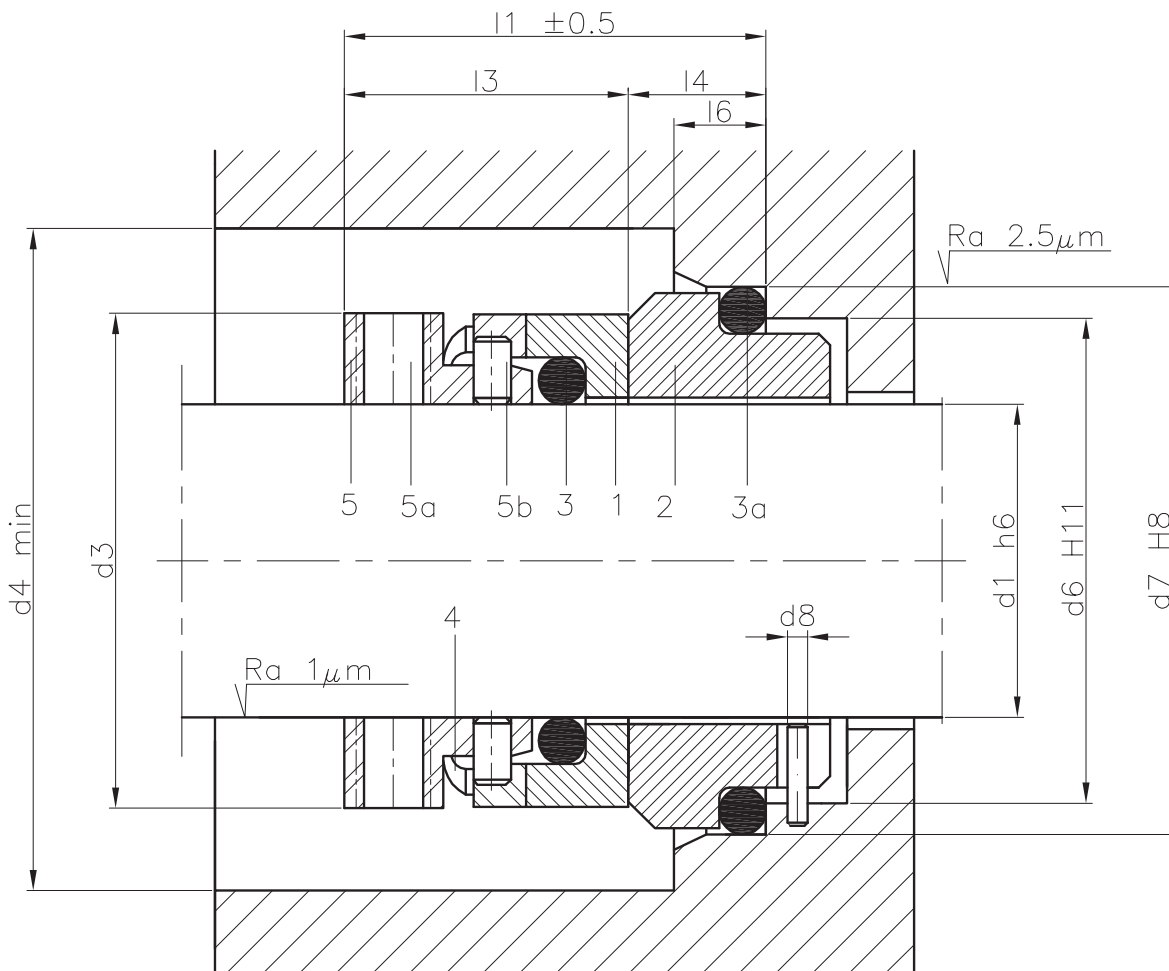

LÍMITES OPERATIVOS / LIMITES D'UTILISATION / OPERATING LIMITS / EINSATZGRENZEN

$d_1 = 16 \div 100 \text{ mm}$

$p/d = 10 \text{ Kg/cm}^2$

$v/g = 15 \text{ m/s}$

$t = -20 \div +200^\circ\text{C}$

Los límites operativos vienen condicionados por el factor PV
 Les limites d'utilisation ci-dessus peuvent varier en fonction du facteur PV
 The operating limits depend on the PV factor
 Die Einsatzgrenzen werden durch den DG-Faktor festgelegt

MATERIALES / MATÉRIAUX / MATERIALS / MATERIALIEN

GBEGG	OBEGG	QOEGG
GBPGG	OBPGG	QOPGG
GBVGG	OBVGG	QOVGG

COMPONENTES / CONSTRUCTION / COMPONENTS / KOMPONENTEN

- 1 Cara de roce rotante / Grain mobile / Rotative face / Rotierende Gleitfläche
- 2 Cara de roce fija / Grain stationnaire / Stationary face / Stationäre Gleitfläche
- 3 Junta tórica / Joint torique / O-ring
- 3a Junta tórica / Joint torique / O-ring
- 4 Muelle / Ressort / Spring / Feder
- 5 Armadura metálica / Corps / Metal frame / Metallgestell
- 5a Tornillo de fijación / Vis d'attache / Set screw / Befestigungsschraube
- 5b Pasador / Goupille (anti-rotation) / Pin / Stift

Existen otras combinaciones de materiales
 Il existe d'autres combinaisons de matériaux
 Available in other materials
 Es gibt andere Materialkombinationen



LIDERING, S.A.

Pg. Ferrocarrils Catalans, 106-108 • 08940 Cornellà de Llobregat BARCELONA

Domestic Sales: 902 480 440

International Sales: +34 93 480 44 22

Fax 93 480 44 04



Pollensa, 2, Ofic. 8. Edif. Artemisa - Tartessos

28290 Las Rozas MADRID

Tel. 902 480 440 • Fax 91 361 40 20

LIDERING, S.A.R.L.

Parc des Aqueducs • Chemin du Favier RD 42 • 69230 Saint-Genis-Laval FRANCE

Tél. 04 72 67 02 67 • Fax 04 78 56 04 08

LIDERING, GmbH

Schiessstraße, 55 • 40549 Düsseldorf DEUTSCHLAND

Tel. 00 34 93 480 44 22 • Fax 00 34 93 480 44 04

S.A. LIDERING N.V.

BP 10 • 1410 Waterloo BELGIQUE-BELGIË

Tél. 00 34 93 480 44 22 • Fax 00 34 93 480 44 04

<http://www.lidering.com>

email: info@lidering.com