



IRIMO

5. TORNILLOS DE BANCO

Tornillos de banco

GUÍA REDONDA

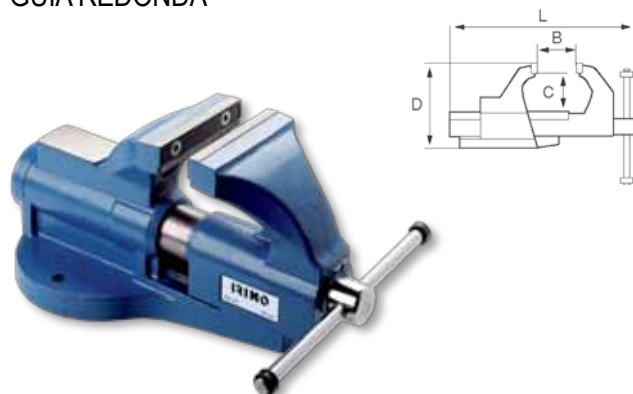

- Tornillo de banco guía redonda
- Fabricado en acero de alta calidad
- Altamente resistente
- Mordazas intercambiables
- Zona de golpeo de mayor superficie
- Husillo con rosca y palanca de giro con suave desplazamiento
- Puede ser utilizado con base giratoria

R	Icono	C mm	B mm	C mm	D mm	L mm	g	€
201231	1	80	90	42	130	260	5.850	182,59
201241	1	100	110	56	166	325	11.350	243,45
201251	1	125	130	72	196	375	18.200	335,31
201261	1	150	170	80	230	430	29.700	476,57

GUÍA CUADRADA, AJUSTE REGULABLE



- Tornillo de banco guía cuadrada
- Fabricado en acero de alta calidad
- Mordazas para tubos
- Mordazas intercambiables
- Zona de golpeo de mayor superficie
- Husillo laminado con rosca y palanca con giro y desplazamiento suave
- Compatible con base giratoria
- Ajuste de guía regulable
- Apoyo de la guía en 4 superficies mecanizadas

R	Icono	C mm	B mm	C mm	D mm	L mm	g	€
216041	1	100	145	50	122	325	6.497	220,48
216051	1	125	170	63	152	402	13.733	296,28
216061	1	150	230	80	182	492	20.388	374,37
216071	1	175	250	94	211	551	30.688	486,90

GUÍA CUADRADA

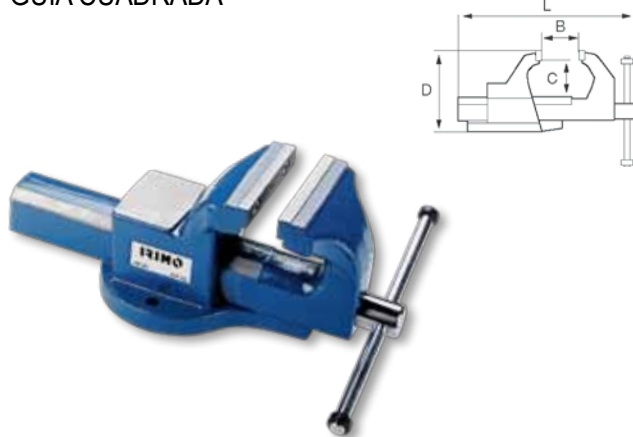

- Tornillo de banco guía cuadrada
- Fabricado en acero de alta calidad
- Alojamiento para mordazas para tubos
- Mordazas intercambiables
- Zona de golpeo de mayor superficie
- Husillo con rosca y palanca con giro suave
- Compatible con base giratoria

R	Icono	C mm	B mm	C mm	D mm	L mm	g	€
207041	1	100	145	50	122	325	6.200	189,49
207051	1	125	170	63	152	402	13.200	265,27
207061	1	150	230	80	182	492	19.800	341,07
207071	1	175	250	94	211	551	30.100	454,76

GUÍA CUADRADA



- Tornillo banco guía cuadrada
- Fundición dúctil para mayor resistencia a impactos, con características similares al acero
- Fijado con la base giratoria
- Yunque cuadrado largo
- Pin sujeción al husillo para evitar la caída de la mordaza
- Mordazas y husillos disponibles
- GS certification

R	Icono	C mm	B mm	C mm	D mm	L mm	g	€
207-100	1	100	100	61	164	144	11.450	120,00
207-125	1	125	125	72	193	169	20.000	180,00
207-150	1	150	150	84	223	195	29.700	235,00

Repuestos

MORDAZAS DE REPUESTO

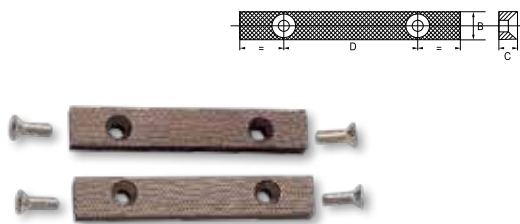

- Pareja de mordazas y tornillos para tornillo guía redonda 201

R		L mm	B mm	C mm	D mm	g	€
202401	1	80	15	10	55	170	17,33
202411	1	100	20	12	64	350	20,84
202421	1	125	20	12	77	450	31,61
202431	1	150	25	14	90	750	37,11

MORDAZAS DE REPUESTO

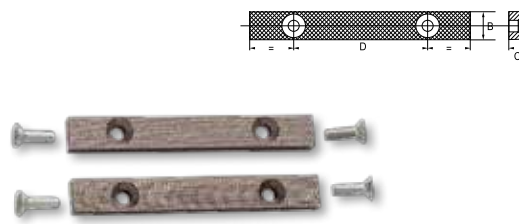

- Pareja de mordazas y tornillos para tornillo guía cuadrada 207041 / 207071 y 216

R		L mm	B mm	C mm	D mm	g	€
202441	1	100	15	10	64	350	20,49
202421	1	125	20	12	77	450	31,61
202451	1	150	20	12	90	750	37,45
202461	1	175	25	14	105	1.020	45,89

MORDAZAS DE REPUESTO

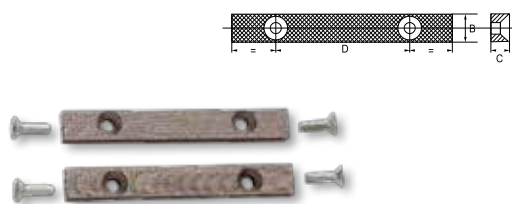

- Par de mordazas con tornillos para tornillo guía cuadrada 207-100 / 207-150

R		L mm	B mm	C mm	D mm	g	€
202-100	1	100	20	10	60	270	15,44
202-125	1	125	21	12	75	460	19,08
202-150	1	150	21	12	90	550	21,87

MORDAZAS PARA TUBO



- Pareja de mordazas de tubo y tornillos para tornillo guía cuadrada 207041 / 207071 y 216

R		L mm	Ø mm	g	€
206721	1	100	13,5 - 26,9	245	25,76
206741	1	125	21,3 - 76,1	436	31,96
206761	1	150 / 175	26,9 - 89,0	478	31,96

HUSILLO Y TUERCA



- Husillo y tornillo para tornillo guía redonda 201

R		L mm	L mm	g	€
202811	1	80	251	875	39,69
202821	1	125	317	1.400	44,48
202831	1	100	364	2.200	63,79
202841	1	150	428	3.400	106,53

HUSILLO Y TUERCA



- Husillo y tuerca para tornillo guía cuadrada 207041 / 207071 y 216

R		L mm	L mm	g	€
206821	1	100	287	600	34,77
206831	1	125	352	1.400	52,09
206841	1	150	432	2.200	90,26
206851	1	175	471	3.200	115,66

Repuestos

HUSILLO Y TUERCA



- Husillo y tuerca para tornillo guía cuadrada 207-100 / 207-150

R			L mm	g	€
206-100	1	100	165	560	17,06
206-125	1	125	188	920	20,66
206-150	1	150	216	1.060	23,04

Accesorios

BASE DE TORNILLO GIRATORIA

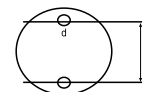

- Base giratoria para todos los modelos de guía redonda 210 y cuadrada 207041 / 207071 y 216

R		Ø mm		L mm	d mm	g	€
201431	1	80	100	90	11	850	47,64
201451	1	100	125	115	13	1.150	74,34
201461	1	125	150	145	13	1.500	83,94
201471	1	150	175	165	17	2.500	109,10

MORDAZAS ALUMINIO DOBLE RANURADO



- Pareja de mordazas protectoras magnéticas: de aluminio con ranurado horizontal y vertical profundo
- Incluye un imán fuerte para encajar fácilmente la mordaza en el acero

R			L mm	g	€
202561	1	100	180	28,92	
202571	1	125	200	29,97	
202581	1	150	220	30,91	

MORDAZAS ALUMINIO RANURADAS



- Pareja de mordazas protectoras magnéticas: de aluminio con ranurado horizontal simple
- Incluye un imán fuerte para encajar fácilmente la mordaza en el acero

R			L mm	g	€
202511	1	100	180	27,63	
202521	1	125	200	28,80	
202541	1	150	220	29,86	

MORDAZAS POLIURETANO



- Pareja de mordazas protectoras magnéticas: de poliuretano con ranurado horizontal y vertical profundo
- Incluye un imán fuerte para encajar fácilmente la mordaza en el acero

R			L mm	g	€
202661	1	100	150	32,78	
202671	1	125	175	34,19	
202681	1	150	200	35,12	

MORDAZAS POLIURETANO



- Pareja de mordazas protectoras magnéticas: de poliuretano con moleteado uniforme
- Incluye un imán fuerte para encajar fácilmente la mordaza en el acero

R			L mm	g	€
202761	1	100	150	31,84	
202771	1	125	175	32,78	
202781	1	150	200	34,06	

Tornillo de sobremesa

TORNILLO DE SOBREMESA DE GUÍA REDONDA

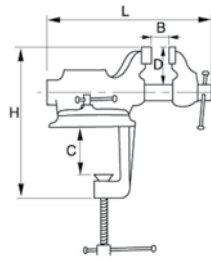

- Husillo protegido
- Giratorio
- Fundición nodular

Q	Icono	mm	B mm	C mm	D mm	H mm	L mm	g	€
217161	1	63	63	75	47	225	210	4.500	94,17

Repuestos

MORDAZAS DE REPUESTO

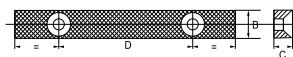

- Par de mordazas y tornillos para tornillo 217

Q	Icono	mm	g	€
217261	1	63	150	15,92

HUSILLO



- Husillo de repuesto para tornillo banco 217

Q	Icono	mm	g	€
217271	1	63	400	34,54

1

2

3

4

5

6

7

8

9

10

11

12

Aprietos de émbolo

APRIETO DE 90 MM

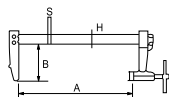
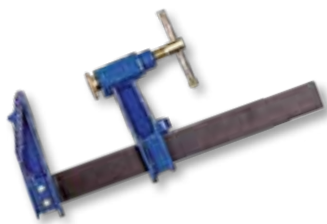

R		A mm	B mm	HxS mm	g	€
256001	5	150	90	30 x 8	1.100	15,92
256011	5	200	90	30 x 8	1.200	17,11
256021	5	250	90	30 x 8	1.300	18,29
256031	5	300	90	30 x 8	1.400	19,25
256041	5	400	90	30 x 8	1.600	21,18

APRIETO DE 120 MM

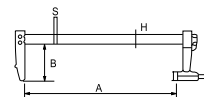
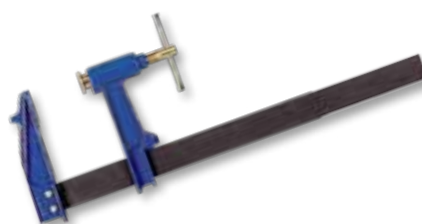

R		A mm	B mm	HxS mm	g	€
256131	5	300	120	35 x 8	2.000	20,74
256141	5	400	120	35 x 8	2.200	22,45
256151	5	500	120	35 x 8	2.400	24,48
256161	5	600	120	35 x 8	2.600	26,08
256181	5	800	120	35 x 8	3.000	29,93
256201	5	1.000	120	35 x 8	3.400	34,01

APRIETO DE 150 MM

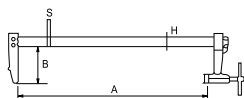

R		A mm	B mm	HxS mm	g	€
256231	5	300	150	40 x 10	3.100	37,10
256241	5	400	150	40 x 10	3.400	39,57
256251	2	500	150	40 x 10	3.700	41,83
256261	2	600	150	40 x 10	4.000	43,77
256281	2	800	150	40 x 10	4.600	47,99
256301	2	1.000	150	40 x 10	5.200	51,67
256321	1	1.200	150	40 x 10	5.800	54,84

TORNIQUETE DE MARQUETERÍA

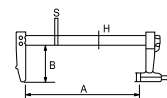
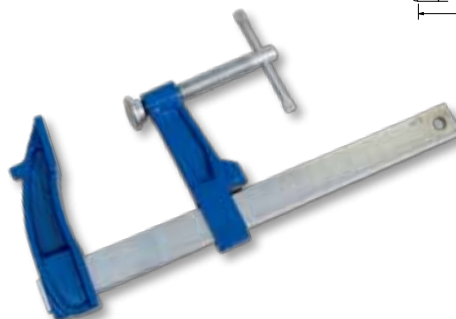

R		A mm	B mm	HxS mm	g	€
255011	10	120	70	18 x 7	420	9,62
255021	10	150	70	18 x 7	450	10,18
255031	10	200	70	18 x 7	500	10,98
255041	10	250	70	18 x 7	550	11,70
255051	10	300	70	18 x 7	600	12,72